

Fuel for the fire

A high performance motor car will not give its best if you try and run it on low-grade fuel. So it is with your Heatmaster it can only reach its high capabilities if you use the best fuel. Your Heatmaster will burn any timber, but hardwoods such as Marri (red gum), "Box Wood" e.g. Grey box & yellow box, Mallee Root, Jarrah, etc are recommended and give the best results. Softwood especially pine should only be used as kindling as it burns quickly and is a pitchy wood which may produce a creosote build up in the flue. Green or wet wood of any type should not be burnt. Green timber has a very high moisture content, burns poorly and will give off resinous unburnt volatiles, which can cause deterioration even to a stainless steel flue.

Warranty.

With over twenty years of manufacturing, Heatmaster take great pride in the quality and performance of our products. To show our commitment to this we offer a 15-year warranty on the firebox with a 12-month warranty on the grate and ashtray (under normal/intended use.)

The Heatmaster open fireplace is intended to add ambience, atmosphere and character to a home, while giving you warmth as a secondary heat source. Although the Heatmaster is a highly efficient open fireplace system it is not intended to be operated as a slow combustion heater or be used as a sole source of heating.

Returns and claims

All items are checked before delivery. Claims for damaged or defective goods must be made within 7 days. Returns will be subject to a minimum handling and repainting fee of \$50 plus transport cost.

HEATMASTER

Warmth Atmosphere Style

Heatmaster National Office

2/9 Nicole Close Bayswater Victoria 3153
Phone: 03 9761 7130 Fax: 03 9761 7134

Heatmaster NSW, Qld, Act

2/23 Victoria Avenue Castle Hill NSW 2154
Phone: 02 9894 7950 Fax: 02 9894 7265

www.heatmaster.com.au



HEATMASTER

Warmth Atmosphere Style



OPERATING
INSTRUCTIONS

HINTS AND TIPS

Initial fires

Like any new appliance that involves high temperatures, the first few fires in your Heatmaster fireplace will produce odors associated with new metal and paint curing. We suggest that if possible you should light the first fire during the day when windows may be opened to get rid of any odors that may be unpleasant. If possible maintain a small fire for four or five hours this will allow paint to cure better with fewer odors than if you light a big fire.

Lighting the fire

Never start a fire with kerosene or any other flammable liquids. Before burning your first fire make sure you remove the plastic protective coating from the Heatmaster nametag on the ashtray, then be sure that the grate is suspended up on the angle brackets, this will enable the ashtray to easily slide in and out.

When starting your fire take seven or eight double sheets of newspaper and twist them lengthwise into fairly tight rolls. Lay these side by side, lengthwise across the grate. Now build a mound or pyramid of sticks, twigs & kindling across the center of the grate (height say 9-12"). Light the paper at both ends and in the middle. As soon as the kindling has "caught" and is burning briskly, add larger pieces of wood to the fire. When the fire is a merry blaze put on smallish logs.

Remember that with Heatmaster you need a fast fire for the first ten to fifteen minutes. This is to get the heat exchanger up to operating temperature quickly so that the convection or space heating cycle can start. Maintain as big a fire as you need. As the area being heated warms up and air circulation increases, you will be able to run a smaller and slower fire. This is time to put on your larger split timber logs.

Safety & Fire Sense

We suggest if you ever have to extinguish your fire quickly; smother it with loose soil or sand. Only in a case of an emergency try to put the fire out by throwing water on it but this may lead to the development of rust if not dried completely. Most firewood will spit sparks from time to time and these are not kind to carpets. It is strongly recommended to have a fire screen or fireguard with all Heatmasters. You should never leave a lit fireplace unattended.

Maintenance

Remove and clean out the ashtray before its full to the brim! However it is recommended that a bed of ash be left in the bottom of the tray. There should never be any need to disturb the suspended Heatmaster grate. And don't waste the ashes, they're good for the garden, containing lime, potash & phosphorus. The parts of your car that take the worst kind of constant hard wear and abuse are the tyres. With your Heatmaster fireplace it's

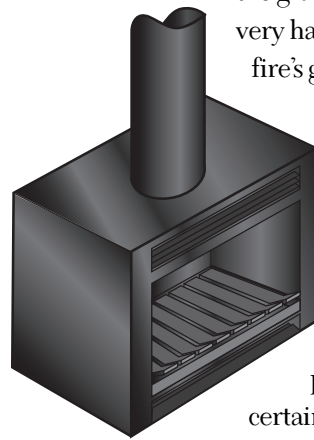

the grate and ashtray which have the very hard and hot life whenever the fire's going. Not surprisingly like the car tyres, the grate and ashtray deteriorate and at some time will need to be replaced. If your grate develops a slight bow in the middle, this is nothing to be alarmed about. The grate is subjected to prolonged and intense heat and a certain amount of warping is normal.

Similarly the ashtray may warp. It is also strongly recommended that in the interests of safety and a long flue life that you have the flue swept and cleaned once a year by a recommended chimney sweep.

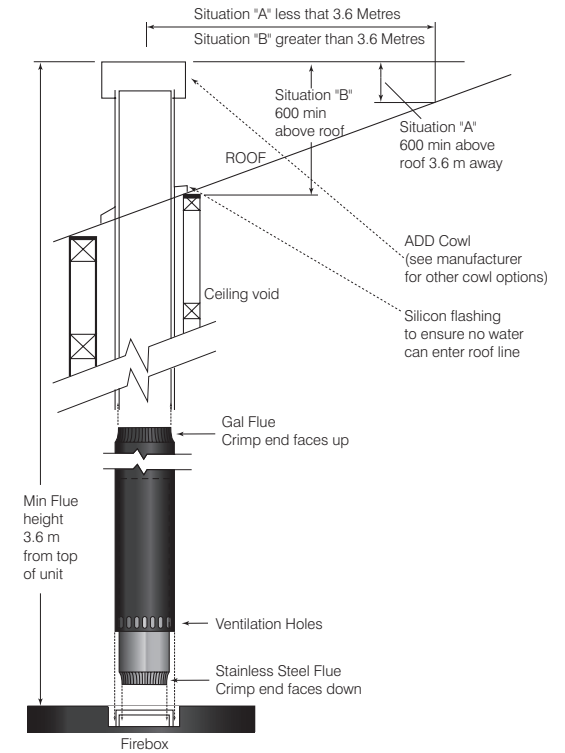

Trouble shooting

If your fireplace is not drawing properly (i.e. smoke entering the room) this is nothing to be alarmed about. There are many causes and many solutions for this occurrence.

Incorrect clearance of flue or close proximity to large trees, tall building or high landmass may contribute. Other contributing factors can simply be the different climates or atmospheric conditions of certain areas.

The solutions are also varied, from adding flue to changing the cowl or even the fuel you are burning. We would ask if you experience a smoking fire, please first check it has been installed correctly, with the proper clearances. If the problem persists, please contact your Heatmaster dealer.